

Pneumatic grease pump 50:1

and grease supply system

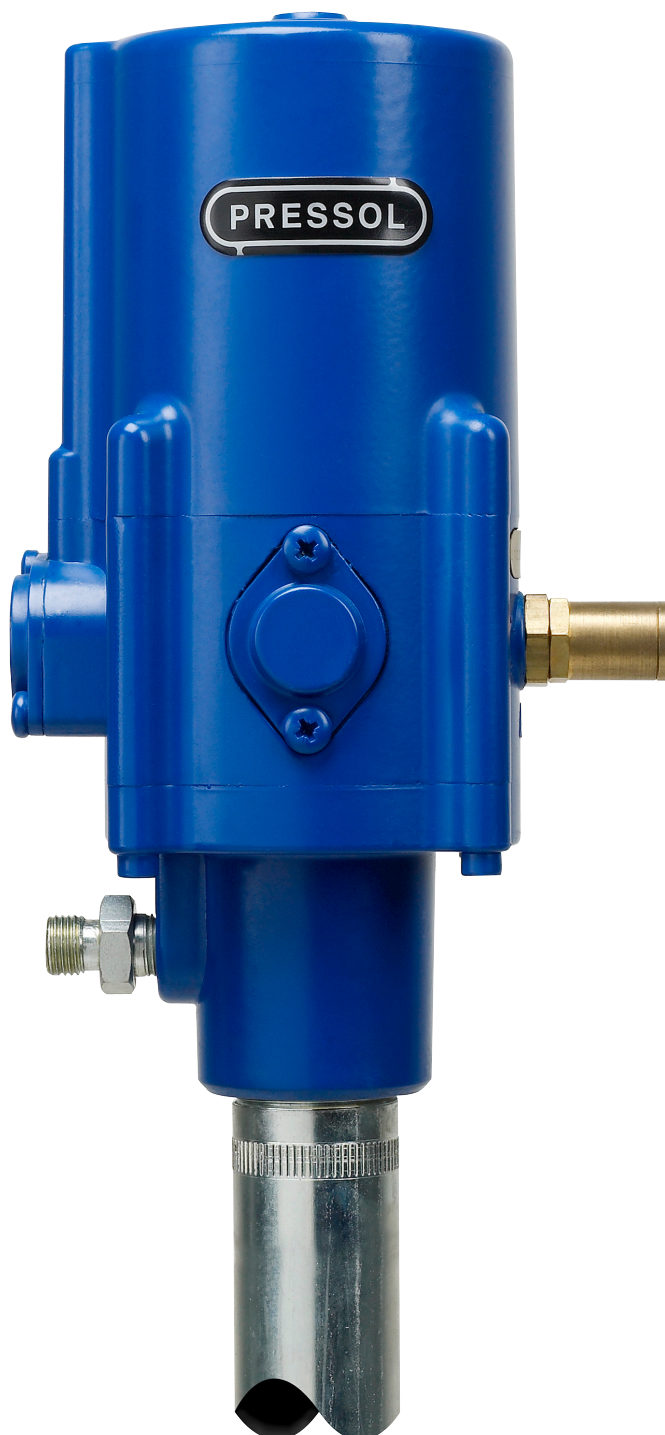

Contents

1.	General Information	2
1.1	Usage Stipulations	2
1.2	Construction & Functional Description	2
1.3	Technical Data	3
1.4	Application Range	3
1.5	Operational Area Requirements	3
1.6	Adjustment of the maintenance unit	4
2.	General Safety Advice	5
2.1	Signs and symbols used in the safety instructions	5
2.2	Information on safety at work	5
2.3	Risks when Working with the grease pump	6
3.	Assembly	7
4.	Preparing for Operation	7
5.	Operation	7
5.1	Replacement of container	8
6.	Maintenance	8
7.	Accessories	9
8.	Troubleshooting	9
9.	Repairs/Service	10
10.	EC Declaration of Conformity	10
11.	Exploded view	11

1. General Information

1.1 Usage Stipulations

This pump is to be used for feeding lubrication greases and multi function greases from NLGI 0 to NLGI 2 from original barrels. It is both designed for use in conjunction with distribution lines or directly on the container.

To ensure that usage stipulations are met, read through the operating instructions completely before using the pump and observe all stipulations.

Any departure from the usage stipulations (other fluid media, use of force) or user modifications (changes, use of non-original parts) can be dangerous and are considered as non-stipulated usage.

The user is liable for any damage resulting from non-stipulated use.

Before commencing any repair or maintenance work, release the pressure from the installation.

Repairs and maintenance are only to be carried out by qualified specialists.

Only original replacement parts are to be used for any repairs, otherwise the warranty will be invalidated.

1.2 Construction & Functional Description

The grease pump can be fitted with a variety of PRESSOL accessories.

The Pump casing is manufactured from die-cast zinc with a hardened stainless steel piston rod and high quality durable synthetic control components.

The polyurethane or Buna N o-rings and washers are designed to meet the operating requirements of the pump.

1.3 Technical Data

Typ		50:1
Transmission ratio		50:1
Maximum air pressure	bar	10
Minimum air pressure	bar	2
Recommended air Pressure	bar	8
Motor Displacement	cm ³	220
Pump Displacement	cm ³	8
Number of strokes at 8 bar *	Strokes/min	220
Pump performance at 8 bar *	g/min	1100
Pump pressure at 8 bar compressed air	bar	400
Air consumption at 8 bar compressed air	l/min	400
Airline connection	G	¼" i
Grease supply connection from the suction side	Ø/mm	35
Grease supply connection from the pressure side	G	¼" a
Noise level on no load, according to ISO 9614-2 (2 m distance)	db (A)	78
Noise level on load, according to ISO 9614-2 (2 m distance)	db (A)	77
Weight	kg	8,4
* under free discharge		

Tab. 1-3: Technical Data

1.4 Application Range

This pump is to be used for feeding lubrication greases and multi function greases from NLGI 0 to NLGI 2 from original barrels.

1.5 Operational Area Requirements

The grease pump is intended for use within a building. The installation area must be selected such that correct operation is ensured.

The pneumatic pump must be used with a maintenance unit otherwise the warranty will be invalid! It is also important to ensure that a pressure control valve is used when the pump is operated. Set the pressure to 8 bar to achieve the recommended operating pressure of the pump. This will prevent possible damage to equipment, pipe leakage and protect the pump.

New installation lines should be cleaned to avoid any residual metal filings damaging individual components within the pump. When changing containers protect the suction tube properly to make sure that the suction tube will not be contaminated by dirt particles, such as metal parts, splinters etc. which will additionally contaminate the lubricant in a new container.

The operator of such an installation is, according to § 19i WHG (Germany) responsible for continuous monitoring to ensure compliance with the above stated requirements at the installation.

1.6 Adjustment of the maintenance unit



Item-Nr: 20 218 950 (old version):

With this maintenance unit the adjusting dial must be set to Position 1 as shown in the diagram.

Screw the brass screw completely in, then unscrew one turn.





Item-Nr: 20 218 950 (new version):

With this maintenance unit the brass screw must be screwed in as explained in the diagram.

2. General Safety Advice

2.1 Signs and symbols used in the safety instructions

The safety instructions used in these operating instructions are divided into various levels of hazard. Various levels of hazard are indicated in the instructions with the following keywords and pictograms:

Pictogram	Keyword	Consequences of failure to comply with the safety instructions
	Warning	Possible death or serious injury
	Caution	Possible slight or not serious injury or material damage

In addition, a further instruction is used which gives general tips for handling the product.

Pictogram	Keyword	Meaning
	Tip	Background information or tips about how to use the product

2.2 Information on safety at work

The grease pump has been designed and manufactured according to the health and safety requirements of the relevant EC guidelines.

Nevertheless, there can still be risks if the product is not set up or operated as stipulated.

Therefore, before using the grease pump, read these operating instructions and pass them on to other users of the pump.

When operating the grease pump, the local safety and accident prevention rules and regulations always apply, as well as the safety advice in the operating instructions.

Only approved PRESSOL maintenance personnel should open or repair pumps within the guarantee period.

Attention! The compressed air line must be disconnected and the discharge pistol actuated to ensure that the pump is depressurised before the pump unit is opened or inspected. For safety reasons the compressed air line should be disconnected when the pump is not in use otherwise the pump will remain pressurised.



Caution!

If the grease pump is incorrectly installed, or used for a purpose other than that originally intended for, it can result in personal injury or damage to equipment!

Before starting to use the grease pump, read through these operating instructions carefully and completely.

2.3 Risks when Working with the grease Pump



Warning!

Damaged attachments and accessories can lead to personal injury and material damage!

- Suction and pressure pipes must not be kinked, twisted or stretched.
- Attachments and accessories must be checked for wear, splits or other damage at all times.
- Defective accessories are to be replaced immediately only by Original-PRESSOL-Spareparts.
- With reference to the period of use, please note the details in ZH 1/A45.4.2 or DIN 20066 Part 5.3.2.



Caution!

Spilled fuel can result in environmental damage!

- Local and country rules and regulations relating to domestic water supplies and fuel storage must be obeyed.



Caution!

Overpressure may cause damages of grease gun head and its accessories!

- Do not exceed the working pressure stated in chapter 1.3.
- We recommend the use of original accessories according to DIN 1283 only.



Caution!

Overpressure at the point of lubrication may destroy the grease nipple and perhaps even the bearings or the machine itself!

- Do not exceed the working pressure stated in chapter 1.3.
- Note the maintenance and service instructions of the manufacturer of your machine.

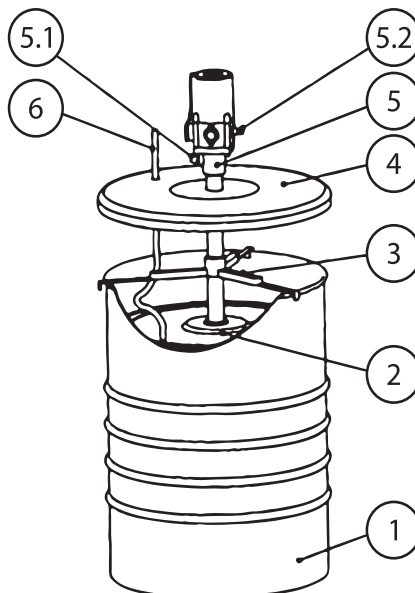

3. Assembly

The grease pump will be delivered completely assembled.

Accessories might need to be fitted depending on the version used.



Tip

Ensure cleanliness during assembly and that all accessories are correctly connected to the pump.

Please use suitable sealing material (e.g. Teflon film), only.

Remove the dust cover from the container and insert the follower plate (Pos. 1) slightly tilted. Then push the follower plate against the grease until grease emerges from the central opening.

Fix the stabilising fixing brackets (Pos. 3) on the grease container (Pos. 1) and adjust the stabilising fixing brackets above the central opening of the follower plate (Pos. 2).

Push the dust cover (Pos. 4) onto the pipe of the grease pump (Pos. 5) and insert the pipe through the stabilising fixing brackets (Pos. 3) and through the follower plate (Pos. 2) to the grease container (Pos. 1).

Fix the grease hose with all its corresponding accessories (swivel joint, high pressure grease control gun, etc.) onto the pump exit (Pos. 5.1).

The grease pump is now ready for operation.

4. Preparing for Operation



Caution!

Never work on a pump that is running!

- Mount or remove attachments and accessories only when the pump is switched off.

Connect the compressed air connection (Pos. 5.2) of the grease pump with the air supply line. The pump now starts to run.

Operate the high pressure grease control gun until the grease flows out without air bubbles.

Stop operating the high pressure grease control gun. The pump stops automatically when the set working pressure is reached.

The grease pump is now ready for operation.

5. Operation



Warning!

The pump supplies a working pressure of 400 bar!

- While working with the pump please wear suitable safety equipments (leather gloves, protective glasses).
- Never point the high pressure grease control gun at parts of your own body or on other persons standing nearby.



Caution!

Do not pump contaminated materials!

- Please ensure that the grease to be pumped contains no contaminants.

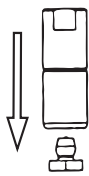

Fig. 5-1



Fig. 5-2

Press the hydraulic coupler onto the grease nipple in axial direction. (Fig. 5-1)

Operate the high pressure grease control gun until the required amount of grease has been delivered.

Disconnect the hydraulic coupler from the grease nipple by moving the hydraulic coupler in circles. (Fig. 5-2)

i Tip

Disconnect the quick coupler of the grease gun from the compressed air supply if the greasing procedure has been achieved or if the pneumatic grease gun is not to be used for a while, to avoid an unintentional discharge of the grease cartridge or to prevent leakage.

5.1 Replacement of container

! Caution!

Never work on a pump that is running!

- Replace the container only when the pump is switched off and only when there is no more air pressure in the system.

Disconnect the quick coupler of the grease gun from the compressed air supply.

Operate the high pressure grease control gun until grease flow stops.

When using 200 l container the follower plate (Pos. 2) can be removed from the bottom of the container by using compressed air supply. In order to achieve this blow compressed air through the hose (Pos. 6) under the follower plate by means of an air gun.

Uninstall the grease pump, the dustcover, the stabilizing fixing brackets and the follower plate in reverse sequence as described under step 3 (assembly).

i Tip

Do not place the pump with its pipe directly onto the floor. Protecting the pump from dust will avoid possible damage on the system as well as maintenance time and after sales service costs.

6. Maintenance

The muffler and air inlet filter should be cleaned regularly to maintain the trouble free performance of the pump. If the pump is not used with a maintenance unit, frequently lubricate the pump by inserting 2 to 3 drops of quality oil through the air inlet connector at regular intervals.

The grease pump is very easy to maintain and service.

Due to the operator responsibilities according to § 19i WHG (German rules), the following components must be regularly checked and replaced as necessary, to minimise the possibility of environmental or equipment damage, or personal injury:

- Pump housing
- Delivery hose
- Nozzle valve
- Connection lines

7. Accessories

See catalogue Garage equipment or www.pressol.com

Tip

Only with original-PRESSOL spare parts is perfect operation of your grease pump guaranteed! To avoid faulty operation and danger, please use only original spare parts.

8. Troubleshooting

Problem	Cause	Solution
The pneumatic unit runs slowly or not at all.	The air pressure is too low.	Set the air supply to a minimum pressure of 3 bar.
	The muffler (pos. 20) or the filter (pos. 11) is obstructed or dirty.	Clean the muffler and filter.
The pneumatic unit is running but the pump is operating too slow or not at all.	Sieve (Pos.41) foul.	Sieve must be cleaned up.
	Grease container dented.	Press the follower plate underneath the dent.
	Air bubbles in the grease.	Remove the pump from the container. Push the container several times on the floor. Press down the follower plate and replace the pump into the container. Operate the high pressure grease control gun and connect the compressed air.
	Grease too stiff.	Use only grease up to consistency grade NLGI 2. Do not use grease below temperature of 15°C.
	Friction loss in the delivery hose.	Select if possible only short hoses and insert the pump centrally.
The pump runs but no pressure is generated.	The o-rings, washers or valves of the pump are damaged or dirty.	Clean or replace the relevant components.
Air escapes from the muffler when the pump is not operating.	The plunger (pos. 5) is damaged.	Replace the plunger (Art.-Nr. 03 324).
	The o-rings or the distributor seal (pos. 19.6) are damaged.	Replace the components utilising the complete repair kit (Art.-Nr. 87 351)

Tab. 8-1: Fault Finding

If the solutions given in Tab. 8-1 for solving faults do not solve the problem, please contact our customer service (Address, See Chap. 9).

9. Repairs/Service

The grease pump was developed and produced according to the highest quality standards.

Should a problem develop, despite all quality controls, please contact our customer service:

PRESSOL Schmiergeräte GmbH

Tel +49 9462 17-216

Fax +49 9462 1063

service@pressol.com

10. EC declaration of conformity

We hereby state that the appliance described below, in the model which we have made commercially available, complies in its design and construction with the EU directives. If a change has been made to the appliance, and this has not been agreed with us, this statement loses its validity.

Designation of the appliance	Pneumatic grease pump 50:1
Appliance type	Pneumatic pump
Year built	See identification plate
Applicable EC-Directives	EU-Directive Machines annex 1 89/392 EEC-Directive dated September, 14th. 1989 91/368 EEC-Directive dated June, 6th. 1991 93/68 EEC-Directive dated August, 30th. 1993
Applicable national standards	DIN EN 292, part 1, part 2 DIN EN 45014

17.07.2013

PRESSOL Schmiergeräte GmbH



Dipl.-Ing. Rudolf Schlenker

11. Exploded view

No.	Description	Prod. no.
1	Upper casing	03 268
2	O-ring	03 316
3	Locking nut	03 311
4	Washer	87 116
5	Plunger	03 324
6	Compensating washer	03 250
7	Screw	87 221
8	Washer	87 212
9	O-ring	02 380
10	Intermediate casing	87 211
11	Filter	87 228
12	Reducing connector	03 319
13	Control lever	87 210
14	Sleeve	87 209
15	Compression spring	87 215
16	O-ring	87 223
17	Insert	87 206
18	Screw	87 220
19	Distributor repair kit	87 351
19.1	Clamp	87 214
19.2	Sliding disc	87 213
19.3	O-ring	87 225
19.4	O-ring	87 224
19.5	O-ring	87 223
19.6	Distributor	87 204
20	Muffler	87 227
21	Retainer	87 207
22	Piston rod repair kit	87 352
22.1	O-ring	03 262
22.2	Piston rod	87 205
22.3	Slider	87 208
22.4	Piston rod	02 840
23	O-ring	87 226
24	Connecting flange repair kit	87 355
24.1	Connecting flange	87 216
24.2	Bearing	03 307
24.3	O-ring	02 380
24.4	Washer	87 262
24.5	Support washer	03 292

No.	Description	Prod. no.
24.6	Lip washer	03 387
24.7	Circlip	03 264
25	Screw	87 222
26	Locking pin	03 260
27	Compression rod	
	Length 176 mm	87 515
	Length 238 mm	87 516
	Length 376 mm	87 517
	Length 476 mm	87 518
	Length 776 mm	87 519
28	Ball bearing	03 304
29	Pressure piston	87 508
30	Locking nut	00 808
31	Threaded rod	87 509
32	O-ring	87 521
33	Suction tube	
	Length 229 mm	87 510
	Length 291 mm	87 511
	Length 429 mm	87 512
	Length 529 mm	87 513
	Length 829 mm	87 514
34	Adapter	87 507
35	Lip washer	87 522
36	Upper casing	87 506
37	Circlip	03 501
38	Lip washer	00 152
39	Valve cone	03 477
40	Valve body	87 505
41	Sieve	03 503
42	Circlip	03 328
43	Washer	87 528
44	Locking nut	01 085
45	Suction sleeve	87 504

Tab. 11-1: Index to Fig 11-1

Operating instructions for Pneumatic grease pump 50:1 ^{GB}

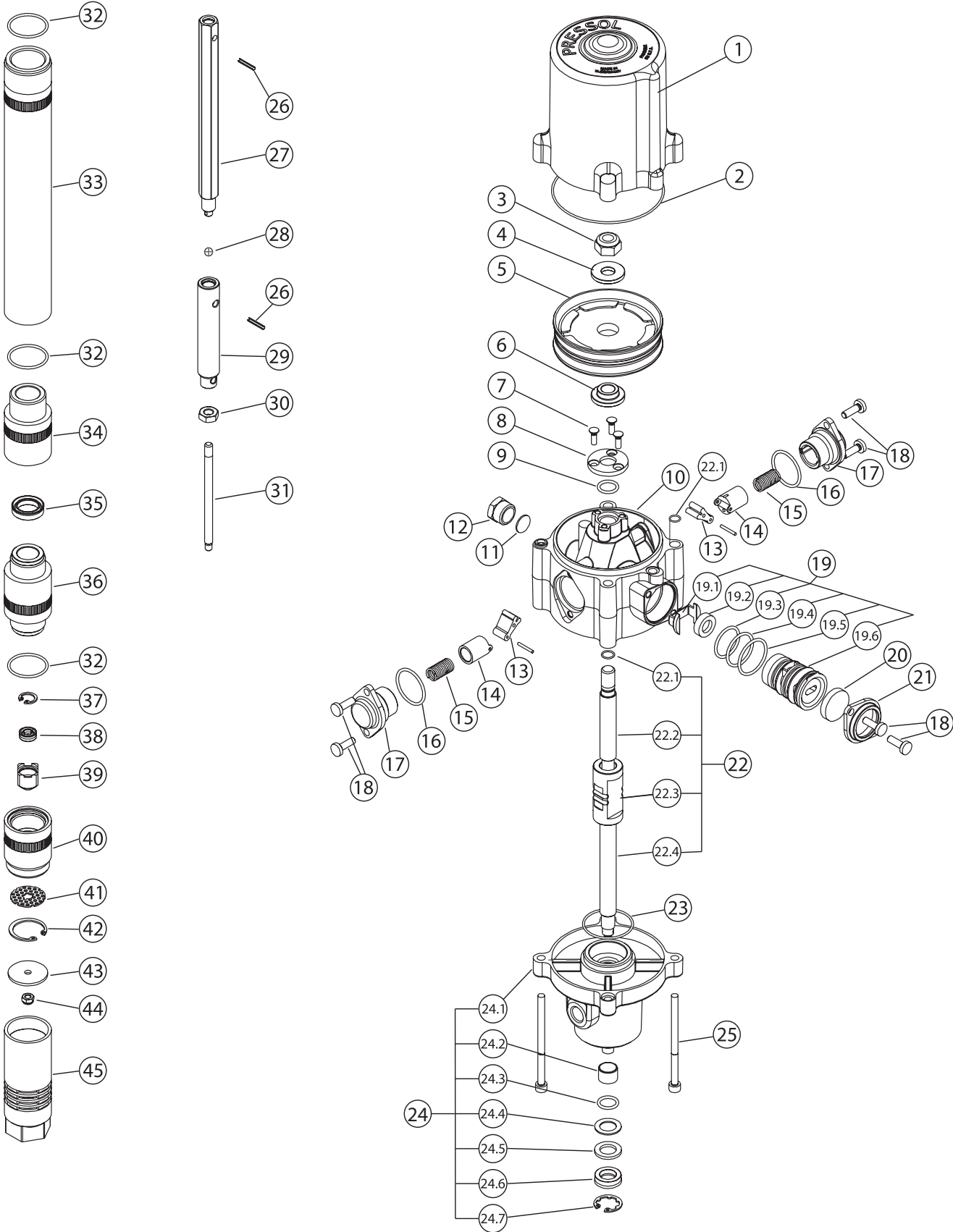

Fig 11-1: Exploded View of the Pneumatic grease pump

Pressol Schmiergeräte GmbH

Parkstraße 7

93167 Falkenstein | Germany

Tel. +49 9462 17-0

Fax +49 9462 17-208

info@pressol.com

www.pressol.com

